

Grinding wheel shape according to FEPA 14F1

WINTER

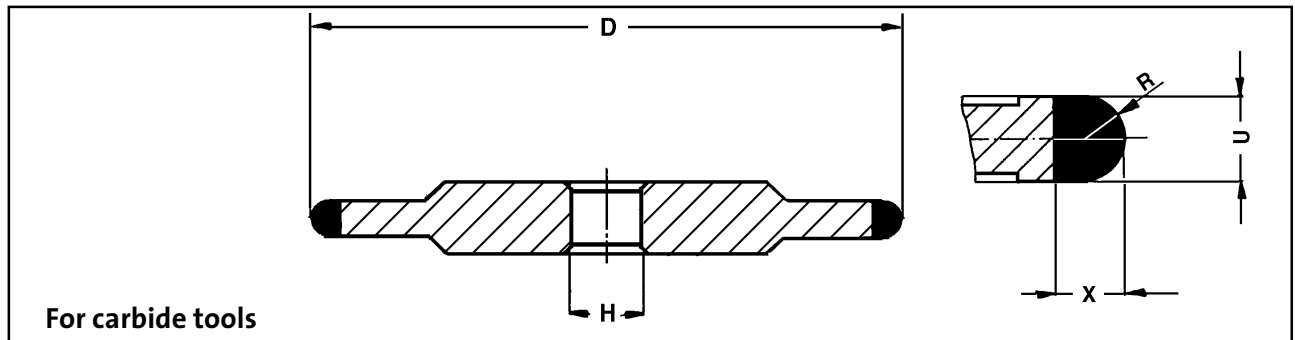

For carbide tools

Shape	- D - U - X - R - H	Grit size	Bond	Concentration	ORDER NO.	Remarks
1K 14F1	- 100 - 4 - 6 - 2 - 20	D64	K-PLUS 1421 R	C100H	82114865	
1K 14F1	- 125 - 8 - 10 - 4 - 20	D64	K-PLUS 1414 J	C75A	82164302	
K 14F1	- 150 - 1.2 - 5 - 0,6 - 20	D46	K-PLUS 888 R	C100A	82144635	Hertel SE drill
K 14F1	- 150 - 2 - 5 - 1 - 20	D64	K-PLUS 888 R	C100A	82139570	Hertel SE drill
K 14F1	- 150 - 4 - 5 - 2 - 20	D64	K-PLUS 1421 R	C100A	82145278	Hertel SE drill
K 14F1	- 150 - 5 - 7 - 2,5 - 20	D64	K-PLUS 1421 R	C100A	82147273	

For HSS tools

Shape	- D - U - X - R - H	Grit size	Bond	Concentration	ORDER NO.	Remarks
K 14F1	- 100 - 3 - 5 - 1,5 - 20	B107	KSS 12 N	V240A	82116858	
K 14F1	- 100 - 4 - 5 - 2 - 20	B107	KSS 12 N	V240A	82116860	
3K 14F1	- 125 - 4 - 5 - 2 - 20	B107	KSS 12 N	V240A	82147275	
K 14F1	- 150 - 4 - 5 - 2 - 20	B107	KSS 12 N	V240A	82147276	

Application depending on software of machine manufacturer:
For point thinning of major cutting edges, for grinding end cutting edges and corner radii, Hertel SE drill, profile grinding.