

Grinding wheel shape according to FEPA 6A9 / 12A9

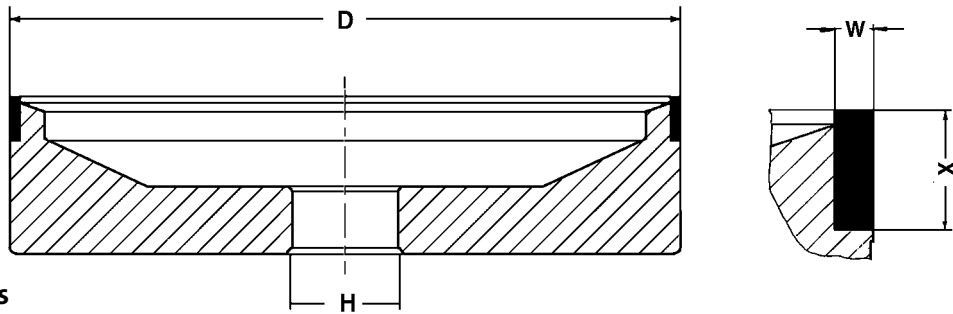

For carbide tools

Shape	- D - W - X - H	Grit size	Bond	Concentration	ORDER NO.	Remarks
11K 6A9	- 100 - 3 - 10 - 20	D64	K-PLUS 1421 R	C100H	82114869	
1K 6A9	- 125 - 3 - 10 - 20	D126	K-PLUS 920	C100A	80124061	

Application depending on software of machine manufacturer:
For grinding 1st and 2nd relief, periphery, minor cutting edge, full radii corner chamfers of drills and milling cutters.

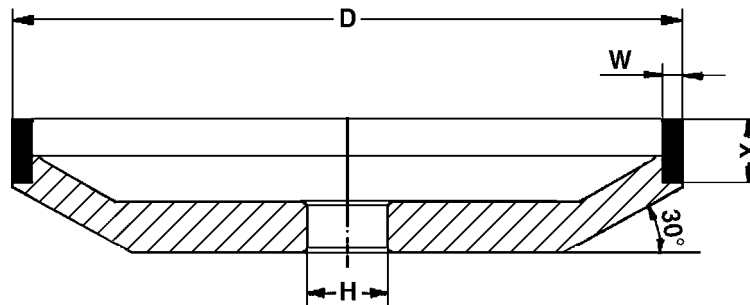

For carbide tools

Shape	- D - W - X - H	Grit size	Bond	Concentration	ORDER NO.	Remarks
1K 12A9	- 150 - 4 - 14 - 20	D46	K-PLUS 1421 R	C100A	82147360	

Application depending on software of machine manufacturer:
For grinding drills and step drills, Sandvik-Delta grinding.